

**E N G I N E
A P P L I C A T I O N S
C a t a l o g o 2 0 0 8**



CATALOGO GENERALE 2008



Note tecniche di prodotto

I dati e le caratteristiche tecniche riportate nel presente Catalogo Generale non sono impegnativi. La SPERONI S.p.a. si riserva il diritto di apportare qualsiasi modifica senza alcun preavviso. Per tanto pesi, misure, prestazioni e quanto altro indicato non sono vincolanti, ma solo indicativi. In ogni caso, per qualsiasi dettaglio tecnico richiedere direttamente alla SPERONI S.p.a. la scheda tecnica aggiornata del prodotto.

Foro Competente

Per eventuali controversie, il Foro competente sarà quello di Reggio Emilia anche se il pagamento è avvenuto a mezzo tratta.

Technical Characteristics

The technical data and characteristics stated in this General Catalogue are not binding. SPERONI S.p.a. reserves the right to make modifications without notice. Therefore weights, dimensions, performances and any other stated issues are indicative only and not binding. Anyway for any technical details you must require an up-to-date product technical card.

Competent Court

In case of any dispute the competent Court will be one of Reggio Emilia even if the payment is by bill of exchange.

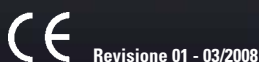

pag. 2

MSA 50



pag. 11

LC 3800 DDC



pag. 20

GF 5500 CXE



pag. 3

MSA 80



pag. 12

LC 5000 DDC



pag. 21

GF 5500 CXE-3



pag. 4

MSHP 50



pag. 13

LC 6500 DDC



pag. 22

HL 5000 SE



pag. 5



MSHP 50-T

pag. 14

LC 6500 DDC-3



pag. 23

HL 5000 SE-3



pag. 6

HL 50 CLA



pag. 15

LC 6500 DDC-Z SELF START



pag. 24

HL 5000 SE/A



pag. 7

HL 80 CLE



pag. 16

LC 8000 DDC



pag. 25

HL 5000 SE-3/A



pag. 8

HL 100 CLE



pag. 17

LS 2700



pag. 26-27-28

**LD 12/186
LD 15/220
LD 18/248**



pag. 9

HL 50 CXLE



pag. 18

LS 4200-E



pag. 29-30

**LGM 200 - B
HGM 180 - D**



pag. 10

LC 2500 DC



pag. 19

LS 6000-E



pag. 32-37

MOTORI/ENGINE



BENZINA/GASOLINE

DIESEL

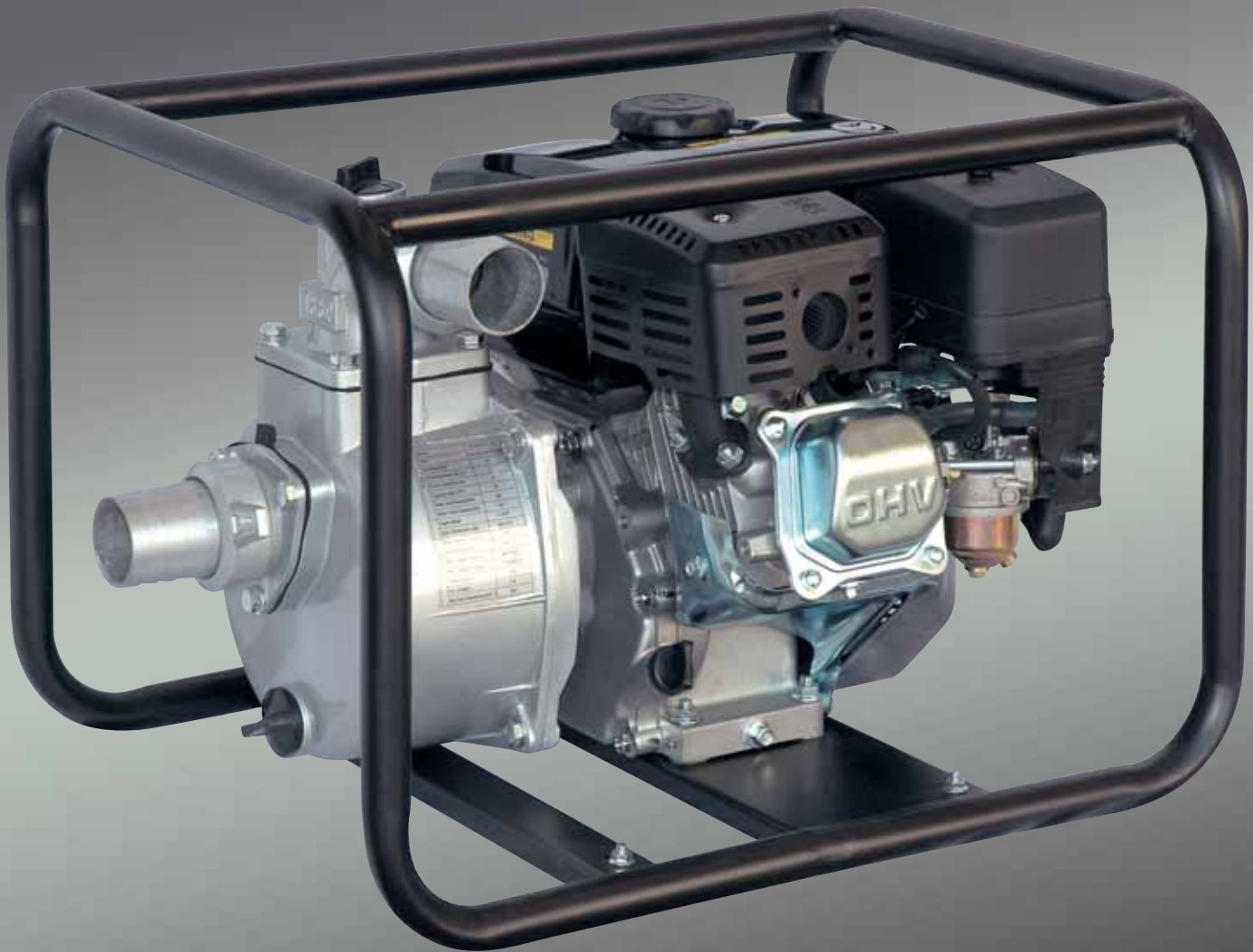
MSA 50

Diametro aspirazione - <i>Suction diameter</i>	50 (2")
Diametro mandata - <i>Discharge diameter</i>	50 (2")
Giri/min - r.p.m.	3600
Portata max. - <i>Delivery max.</i>	550 l/min
Prevalenza max. - <i>Head max.</i>	29 m
Altezza aspirazione - <i>Suction depth</i>	7 m
Tipo motore <i>Engine model</i>	Monocilindrico, benzina, 4-tempi <i>Single cylinder, gasoline, 4-stroke</i>
Potenza motore - <i>Motor power</i>	5,5 hp
Capacità serbatoio - <i>Tank capacity</i>	3,6 lt
Avviamento - <i>Start system</i>	manuale / <i>recoil</i>
Dimensioni - <i>Dimensions</i>	565x445x420 mm
Peso - <i>Weight</i>	24 kg

Motopompe a benzina

Motopompe autoadescanti portatili, particolarmente adatte per l'approvvigionamento e la distribuzione di acque pulite e chiare in agricoltura e in giardino dove non è possibile un collegamento elettrico.

Gasoline water pump

Selfpriming hand-carry motor pumps. Particularly suitable to supply and distribute clean water for agricultural and gardening purposes, when an electrical connection is not possible.

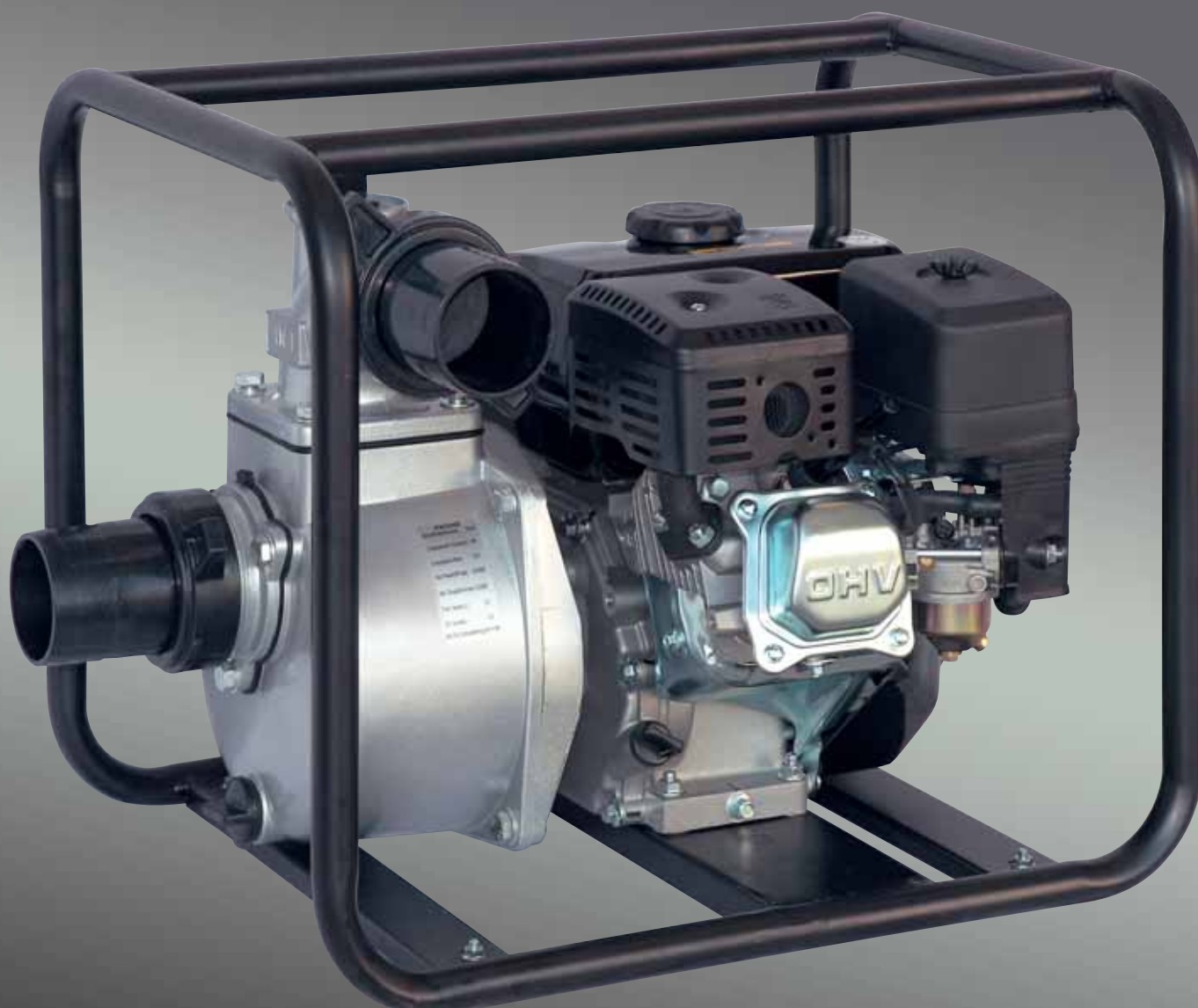
MSA 80

Diametro aspirazione - <i>Suction diameter</i>	80 (3")
Diametro mandata - <i>Discharge diameter</i>	80 (3")
Giri/min - r.p.m.	3600
Portata max. - <i>Delivery max.</i>	900 l/min
Prevalenza max. - <i>Head max.</i>	29 m
Altezza aspirazione - <i>Suction depth</i>	7 m
Tipo motore <i>Engine model</i>	Monocilindrico, benzina, 4-tempi <i>Single cylinder, gasoline, 4-stroke</i>
Potenza motore - <i>Motor power</i>	6,5 hp
Capacità serbatoio - <i>Tank capacity</i>	3,6 lt
Avviamento - <i>Start system</i>	manuale / <i>recoil</i>
Dimensioni - <i>Dimensions</i>	550x430x470 mm
Peso - <i>Weight</i>	28 kg

Motopompe a benzina

Motopompe autoadescanti portatili, particolarmente adatte per l'approvvigionamento e la distribuzione di acque pulite e chiare in agricoltura e in giardino dove non è possibile un collegamento elettrico.

Gasoline water pump

Selfpriming hand-carry motor pumps. Particularly suitable to supply and distribute clean water for agricultural and gardening purposes, when an electrical connection is not possible.

MSHP 50

Diametro aspirazione - <i>Suction diameter</i>	50 (2")
Diametro mandata - <i>Discharge diameter</i>	50 (2")
Giri/min - r.p.m.	3600
Portata max. - <i>Delivery max.</i>	300 l/min
Prevalenza max. - <i>Head max.</i>	80 m
Altezza aspirazione - <i>Suction depth</i>	7 m
Tipo motore <i>Engine model</i>	Monocilindrico, benzina, 4-tempi <i>Single cylinder, gasoline, 4-stroke</i>
Potenza motore - <i>Motor power</i>	6,5 hp
Capacità serbatoio - <i>Tank capacity</i>	3,6 lt
Avviamento - <i>Start system</i>	manuale / recoil
Dimensioni - <i>Dimensions</i>	530x435x480 mm
Peso - <i>Weight</i>	39 kg

Motopompe a benzina

Motopompe autoadescanti portatili, per l'approvvigionamento e la distribuzione di acque pulite e chiare in agricoltura e in giardino dove non è possibile un collegamento elettrico. Particolarmente adatte per impianti antincendio.

Gasoline water pump

Selfpriming hand-carry motor pumps. Particularly suitable to supply and distribute clean water for agricultural and gardening purposes, when an electrical connection is not possible. Suitable for medium sprinkler irrigation and for fire-fighting systems.



MSHP 50 - T

Diametro aspirazione - <i>Suction diameter</i>	50 (2")
Diametro mandata - <i>Discharge diameter</i>	50 (2")
Giri/min - r.p.m.	3600
Portata max. - <i>Delivery max.</i>	300 l/min
Prevalenza max. - <i>Head max.</i>	80 m
Altezza aspirazione - <i>Suction depth</i>	6 m
Tipo motore <i>Engine model</i>	Monocilindrico, benzina, 4-tempi <i>Single cylinder, gasoline, 4-stroke</i>
Potenza motore - <i>Motor power</i>	6,5 hp
Capacità serbatoio - <i>Tank capacity</i>	3,6 lt
Avviamento - <i>Start system</i>	manuale / <i>recoil</i>
Dimensioni - <i>Dimensions</i>	860x680x880 mm
Peso - <i>Weight</i>	68 kg

Kit motopompa antincendio

Completo di: motopompa MSHP 50, carrello con avvolgitubo, 20m tubo manichetta con lancia, 6m set aspirazione 2".

Kit fire fighting water pump

Complete with: gasoline engine pump MSHP 50, trolley with hose reel, mt.20 flexible hose with lance, mt.6 suction set 2".



HL 50 CLA

Diametro aspirazione - <i>Suction diameter</i>	50 (2")
Diametro mandata - <i>Discharge diameter</i>	50 (2")
Giri/min - r.p.m.	3000
Portata max. - <i>Delivery max.</i>	700 l/min
Prevalenza max. - <i>Head max.</i>	26 m
Altezza aspirazione - <i>Suction depth</i>	7 m
Tipo motore - <i>Engine model</i>	DIESEL
Potenza motore - <i>Motor power</i>	4,2 hp
Capacità serbatoio - <i>Tank capacity</i>	12,5 lt
Avviamento - <i>Start system</i>	manuale / recoil
Dimensioni - <i>Dimensions</i>	480x455x580 mm
Peso - <i>Weight</i>	41 kg

Motopompa diesel

Motopompe autoadescanti portatili, particolarmente adatte per l'approvvigionamento e la distribuzione di acque pulite e chiare in agricoltura e in giardino dove non è possibile un collegamento elettrico.

Selfpriming diesel engine pump

Selfpriming hand-carry motor pumps. Particularly suitable to supply and distribute clean water for agricultural and gardening purposes, when an electrical connection is not possible.

HL 80 CLE

Diametro aspirazione - <i>Suction diameter</i>	80 (3")
Diametro mandata - <i>Discharge diameter</i>	80 (3")
Giri/min - r.p.m.	3000
Portata max. - <i>Delivery max.</i>	1000 l/min
Prevalenza max. - <i>Head max.</i>	31 m
Altezza aspirazione - <i>Suction depth</i>	7 m
Tipo motore - <i>Engine model</i>	DIESEL
Potenza motore - <i>Motor power</i>	6 hp
Capacità serbatoio - <i>Tank capacity</i>	12,5 lt
Avviamento - <i>Start system</i>	manuale / <i>recoil</i> elettrico / <i>electric</i>
Dimensioni - <i>Dimensions</i>	550x455x620 mm
Peso - <i>Weight</i>	54 kg

Motopompa diesel

Motopompe autoadescanti portatili, particolarmente adatte per l'approvvigionamento e la distribuzione di acque pulite e chiare in agricoltura e in giardino dove non è possibile un collegamento elettrico.

Selfpriming diesel engine pump

Selfpriming hand-carry motor pumps. Particularly suitable to supply and distribute clean water for agricultural and gardening purposes, when an electrical connection is not possible.



HL 100 CLE

Diametro aspirazione - <i>Suction diameter</i>	100 (4")
Diametro mandata - <i>Discharge diameter</i>	100 (4")
Giri/min - r.p.m.	3000
Portata max. - <i>Delivery max.</i>	1600 l/min
Prevalenza max. - <i>Head max.</i>	31 m
Altezza aspirazione - <i>Suction depth</i>	7 m
Tipo motore - <i>Engine model</i>	DIESEL
Potenza motore - <i>Motor power</i>	9,6 hp
Capacità serbatoio - <i>Tank capacity</i>	12,5 lt
Aviamento - <i>Start system</i>	manuale / recoil elettrico / electric
Dimensioni - <i>Dimensions</i>	635x465x685 mm
Peso - <i>Weight</i>	75 kg

Motopompa diesel

Motopompe autoadescanti portatili, particolarmente adatte per l'approvvigionamento e la distribuzione di acque pulite e chiare in agricoltura e in giardino dove non è possibile un collegamento elettrico.

Selfpriming diesel engine pump

Selfpriming hand-carry motor pumps. Particularly suitable to supply and distribute clean water for agricultural and gardening purposes, when an electrical connection is not possible.

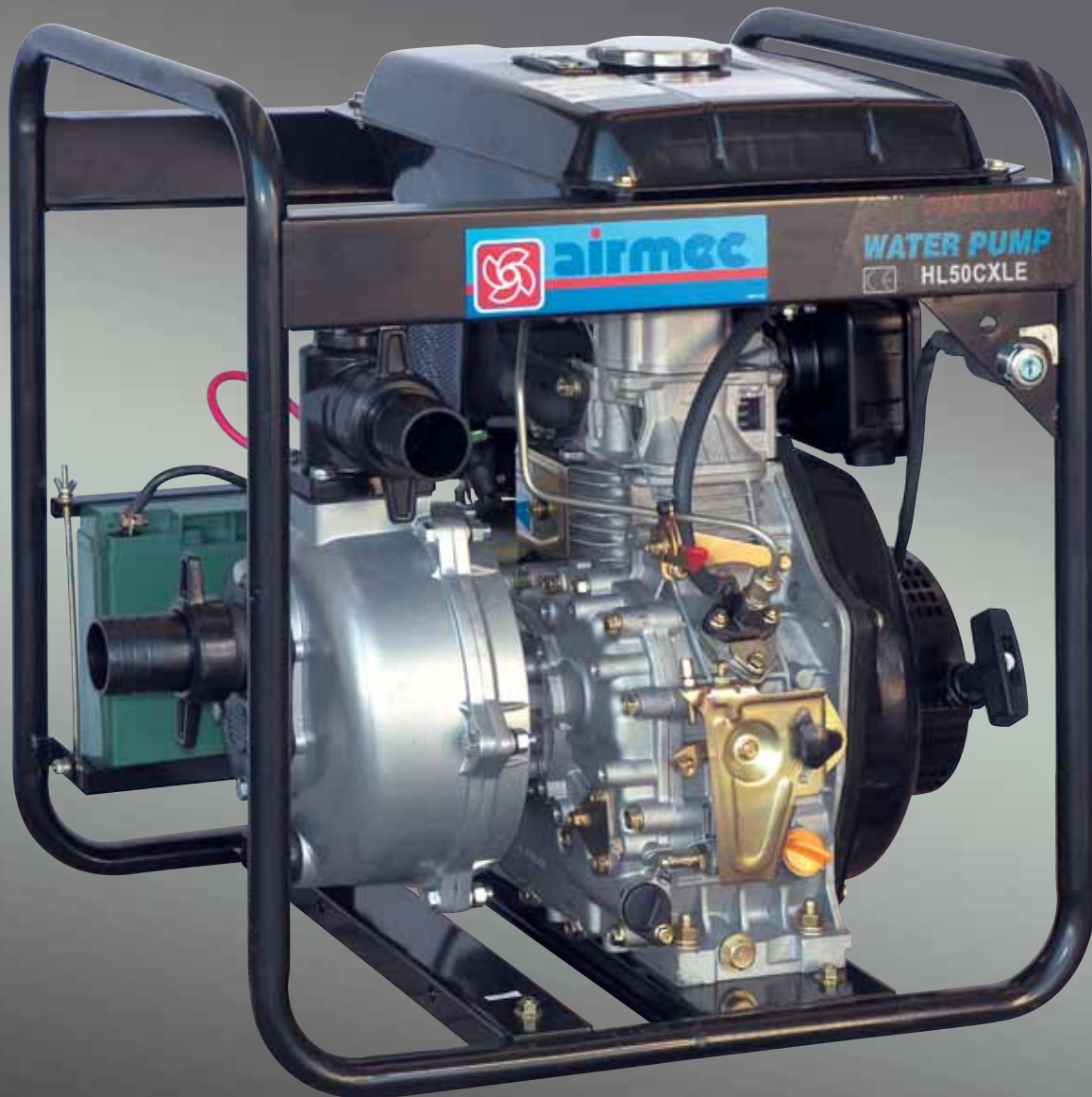

HL 50 CXLE

Diametro aspirazione - <i>Suction diameter</i>	50 (2")
Diametro mandata - <i>Discharge diameter</i>	50 (2")
Giri/min - r.p.m.	3000
Portata max. - <i>Delivery max.</i>	400 l/min
Prevalenza max. - <i>Head max.</i>	50 m
Altezza aspirazione - <i>Suction depth</i>	7 m
Tipo motore - <i>Engine model</i>	DIESEL
Potenza motore - <i>Motor power</i>	6 hp
Capacità serbatoio - <i>Tank capacity</i>	12,5 lt
Avviamento - <i>Start system</i>	manuale / <i>recoil</i> elettrico / <i>electric</i>
Dimensioni - <i>Dimensions</i>	560x455x605 mm
Peso - <i>Weight</i>	75 kg

Motopompa diesel

Motopompe autoadescanti portatili, particolarmente adatte per l'approvvigionamento e la distribuzione di acque pulite e chiare in agricoltura e in giardino dove non è possibile un collegamento elettrico.

Selfpriming diesel engine pump

Selfpriming hand-carry motor pumps. Particularly suitable to supply and distribute clean water for agricultural and gardening purposes, when an electrical connection is not possible.



Motore - Engine		Generatore - Generator	
Potenza <i>Power</i>	6,5	Carica batteria <i>Charging battery voltage</i>	12 V
Aviamento <i>Start system</i>	manuale <i>recoil</i>	Amperaggio <i>Current</i>	8,3 A
Cilindrata <i>Displacement</i>	196 cc	Frequenza <i>Frequency</i>	50 Hz.
Tipo carburante <i>Fuel</i>	benzina <i>gasoline</i>	Tensione <i>Voltage</i>	230 Volt
Capacità serbatoio <i>Tank capacity</i>	15 lt	Potenza uso continuo <i>Continuous duty power</i>	2 kW
Rumorosità <i>Noise ≤7m dB(A)</i>	68	Potenza max <i>Max. power</i>	2,2 kW
Servizio continuo orario <i>Continuous duty running time</i>	12 h	Dimensioni <i>Dimensions</i>	L = 590 P = 475 H = 460
OHV25°, monocilindrico, raffreddamento aria, 4-tempi <i>OHV25°, single cylinder, forced air cooling, 4-stroke</i>		Peso <i>Weight</i>	45 Kg

Generatore a benzina

Gruppo elettrogeno monofase con motore a scoppio 4 tempi a benzina, flangiato ad un alternatore a 2 poli monofase. Aviamento con autoavvolgente. Quadro di comando con 2 prese monofasi e con caricabatteria 12 volt.

Gasoline engine generator

Single phase generating set with 4-stroke gasoline engine coupled to single phase 2-pole alternator. Recoil starter. Control panel with 2 single phase plugs and 12 volt battery-charger.



Motore - Engine		Generatore - Generator	
Potenza Power	8	Carica batteria Charging battery voltage	12 V
Aviamento Start system	manuale elettrico recoil elettric	Amperaggio Current	8,3 A
Cilindrata Displacement	242 cc	Frequenza Frequency	50 Hz.
Tipo carburante Fuel	benzina gasoline	Tensione Voltage	230 Volt
Capacità serbatoio Tank capacity	25 lt	Potenza uso continuo Continuous duty power	2,8 kW
Rumorosità Noise ≤ 7 m dB(A)	72	Potenza max Max. power	3,1 kW
Servizio continuo orario Continuous duty running time	13 h	Dimensioni Dimensions	L = 680 P = 540 H = 550
OHV25°, monocilindrico, raffreddamento aria, 4-tempi OHV25°, single cylinder, forced air cooling, 4-stroke		Peso Weight	72 Kg

Generatore a benzina

Gruppo elettrogeno monofase con motore a scoppio 4 tempi a benzina, flangiato ad un alternatore a 2 poli monofase. Aviamento con autoavvolgente ed elettrico a batteria. Quadro di comando con 3 prese monofase e con caricabatteria 12 volt.

Gasoline engine generator

Single phase generating set with 4-stroke gasoline engine coupled to single phase 2-pole alternator. Recoil or electric starter with battery. Control panel with 3 single phase plugs and 12 volt battery-charger.



Motore - Engine		Generatore - Generator	
Potenza <i>Power</i>	11	Carica batteria <i>Charging battery voltage</i>	12 V
Aviamento <i>Start system</i>	manuale elettrico <i>recoil elettric</i>	Amperaggio <i>Current</i>	8,3 A
Cilindrata <i>Displacement</i>	337 cc	Frequenza <i>Frequency</i>	50 Hz.
Tipo carburante <i>Fuel</i>	benzina <i>gasoline</i>	Tensione <i>Voltage</i>	230 Volt
Capacità serbatoio <i>Tank capacity</i>	25 lt	Potenza uso continuo <i>Continuous duty power</i>	4 kW
Rumorosità <i>Noise ≤7m dB(A)</i>	74	Potenza max <i>Max. power</i>	4,5 kW
Servizio continuo orario <i>Continuous duty running time</i>	10 h	Dimensioni <i>Dimensions</i>	L = 680 P = 540 H = 540
OHV25°, monocilindrico, raffreddamento aria, 4-tempi <i>OHV25°, single cylinder, forced air cooling, 4-stroke</i>		Peso <i>Weight</i>	86 Kg

Generatore a benzina

Gruppo elettrogeno monofase con motore a scoppio 4 tempi a benzina, flangiato ad un alternatore a 2 poli monofase. Aviamento con autoavvolgente ed elettrico a batteria. Quadro di comando con 3 prese monofasi e con caricabatteria 12 volt.

Gasoline engine generator

Single phase generating set with 4-stroke gasoline engine coupled to single phase 2-pole alternator. Recoil or electric starter with battery. Control panel with 3 single phase plugs and 12 volt battery-charger.



Motore - Engine		Generatore - Generator	
Potenza Power	13	Carica batteria Charging battery voltage	12 V
Avviamento Start system	manuale elettrico recoil elettrico	Amperaggio Current	8,3 A
Cilindrata Displacement	389 cc	Frequenza Frequency	50 Hz.
Tipo carburante Fuel	benzina gasoline	Tensione Voltage	230 Volt
Capacità serbatoio Tank capacity	25 lt	Potenza uso continuo Continuous duty power	5 kW
Rumorosità Noise ≤7m dB(A)	76	Potenza max Max. power	5,5 kW
Servizio continuo orario Continuous duty running time	9 h	Dimensioni Dimensions	L = 680 P = 540 H = 540
OHV25°, monocilindrico, raffreddamento aria, 4-tempi OHV25°, single cylinder, forced air cooling, 4-stroke		Peso Weight	90 Kg

Generatore a benzina

Gruppo elettrogeno monofase con motore a scoppio 4 tempi a benzina, flangiato ad un alternatore a 2 poli monofase. Avviamento con autoavvolgente ed elettrico a batteria. Quadro di comando con 3 prese monofasi e con caricabatteria 12 volt.

Gasoline engine generator

Single phase generating set with 4-stroke gasoline engine coupled to single phase 2-pole alternator. Recoil or electric starter with battery. Control panel with 3 single phase plugs and 12 volt battery-charger.



Motore - Engine		Generatore - Generator	
Potenza Power	13	Carica batteria Charging battery voltage	12 V
Aviamento Start system	manuale elettrico recoil elettric	Amperaggio Current	8,3 A
Cilindrata Displacement	389 cc	Frequenza Frequency	50 Hz.
Tipo carburante Fuel	benzina gasoline	Tensione - Voltage Potenza max - Max. power	400 Volt 5,5 kW
Capacità serbatoio Tank capacity	25 lt	Tensione - Voltage Potenza max - Max. power	230 Volt 1,6 kW
Rumorosità Noise ≤7m dB(A)	76	Dimensioni Dimensions	L = 680 P = 540 H = 540
Servizio continuo orario Continuous duty running time	9 h	Peso Weight	90 Kg
OHV25°, monocilindrico, raffreddamento aria, 4-tempi OHV25°, single cylinder, forced air cooling, 4-stroke			

Generatore a benzina

Gruppo elettrogeno trifase con motore a scoppio 4 tempi a benzina, flangiato ad un alternatore a 2 poli trifase. Aviamento con autoavvolgente ed elettrico a batteria. Quadro di comando con 1 presa monofase e 1 presa trifase con caricabatteria 12 volt.

Gasoline engine generator

Three phase generating set with 4-stroke gasoline engine coupled to three phase 2-pole alternator. Recoil or electric starter with battery. Control panel with 1 single phase plug and 1 three phase plug and 12 volt battery-charger.



Motore - Engine		Generatore - Generator	
Potenza <i>Power</i>	13	Carica batteria <i>Charging battery voltage</i>	12 V
Aviamento <i>Start system</i>	manuale elettrico <i>recoil elettric</i>	Amperaggio <i>Current</i>	8,3 A
Cilindrata <i>Displacement</i>	389 cc	Frequenza <i>Frequency</i>	50 Hz.
Tipo carburante <i>Fuel</i>	benzina <i>gasoline</i>	Tensione <i>Voltage</i>	230 Volt
Capacità serbatoio <i>Tank capacity</i>	25 lt	Potenza uso continuo <i>Continuous duty power</i>	5 kW
Rumorosità <i>Noise ≤7m dB(A)</i>	76	Potenza max <i>Max. power</i>	5,5 kW
Servizio continuo orario <i>Continuous duty running time</i>	9 h	Dimensioni <i>Dimensions</i>	L = 680 P = 540 H = 540
OHV25°, monocilindrico, raffreddamento aria, 4-tempi <i>OHV25°, single cylinder, forced air cooling, 4-stroke</i>		Peso <i>Weight</i>	90 Kg

Generatore a benzina

Gruppo elettrogeno monofase con sistema d'avviamento automatico integrato, con motore a scoppio 4 tempi a benzina, flangiato ad un alternatore a 2 poli monofase. Avviamento con autoavvolgente ed elettrico a batteria. Quadro di comando con 2 prese monofase e con caricabatteria 12 volt e scheda carica batteria.

Gasoline engine generator

Single phase generating set complete with automatic starting system, with 4-stroke gasoline engine coupled to single phase 2-pole alternator. Recoil or electric starter with battery. Control panel with 2 single phase plugs and 12-volt battery-charger and battery charger board.



Motore - Engine		Generatore - Generator	
Potenza <i>Power</i>	15	Carica batteria <i>Charging battery voltage</i>	12 V
Aviamento <i>Start system</i>	manuale elettrico <i>recoil electric</i>	Amperaggio <i>Current</i>	8,3 A
Cilindrata <i>Displacement</i>	420 cc	Frequenza <i>Frequency</i>	50 Hz.
Tipo carburante <i>Fuel</i>	benzina gasoline	Tensione <i>Voltage</i>	230 Volt
Capacità serbatoio <i>Tank capacity</i>	25 lt	Potenza uso continuo <i>Continuous duty power</i>	6 kW
Rumorosità <i>Noise ≤7m dB(A)</i>	76	Potenza max <i>Max. power</i>	6,5 kW
Servizio continuo orario <i>Continuous duty running time</i>	8 h	Dimensioni <i>Dimensions</i>	L = 680 P = 540 H = 540
OHV25°, monocilindrico, raffreddamento aria, 4-tempi <i>OHV25°, single cylinder, forced air cooling, 4-stroke</i>		Peso <i>Weight</i>	92 Kg

Generatore a benzina

Gruppo elettrogeno monofase con motore a scoppio 4 tempi a benzina, flangiato ad un alternatore a 2 poli monofase. Aviamento con autoavvolgente ed elettrico a batteria. Quadro di comando con 3 prese monofase e con caricabatteria 12 volt.

Gasoline engine generator

Single phase generating set with 4-stroke gasoline engine coupled to single phase 2-pole alternator. Recoil or electric starter with battery. Control panel with 3 single phase plugs and 12 volt battery-charger.



Standard version



Motore - Engine		Generatore - Generator	
Potenza <i>Power</i>	6,5	Frequenza <i>Frequency</i>	50 Hz.
Avviamento <i>Start system</i>	manuale <i>recoil</i>	Tensione <i>Voltage</i>	230 Volt
Cilindrata <i>Displacement</i>	196 cc	Potenza uso continuo <i>Continuous duty power</i>	2,7 kVA
Tipo carburante <i>Fuel</i>	benzina <i>gasoline</i>	Potenza max <i>Max. power</i>	3 kVA
Capacità serbatoio <i>Tank capacity</i>	3,6 lt	Dimensioni <i>Dimensions</i>	L = 635 P = 490 H = 450
Rumorosità <i>Noise ≤7m dB(A)</i>	70	Peso <i>Weight</i>	41 Kg
Servizio continuo orario <i>Continuous duty running time</i>	3,5 h	OHV25°, monocilindrico, raffreddamento aria, 4-tempi <i>OHV25°, single cylinder, forced air cooling, 4-stroke</i>	

Generatore a benzina

Gruppo elettrogeno monofase con motore a scoppio 4 tempi a benzina, flangiato ad un alternatore a 2 poli monofase. Avviamento con autoavvolgente. Quadro di comando con 2 prese CEE monofase 16A e 1 protettore termico.

Gasoline engine generator

Single phase generating set with 4-stroke gasoline engine coupled to single phase 2-pole alternator. Recoil starter. Control panel with 2 single phase CEE plugs 16A and 1 termic protector.



Standard version



Motore - Engine		Generatore - Generator	
Potenza <i>Power</i>	11	Frequenza <i>Frequency</i>	50 Hz.
Avviamento <i>Start system</i>	manuale elettrico <i>recoil electric</i>	Tensione <i>Voltage</i>	230 Volt
Cilindrata <i>Displacement</i>	337 cc	Potenza uso continuo <i>Continuous duty power</i>	4,2 kVA
Tipo carburante <i>Fuel</i>	benzina <i>gasoline</i>	Potenza max <i>Max. power</i>	4,5 kVA
Capacità serbatoio <i>Tank capacity</i>	6,5 lt	Dimensioni <i>Dimensions</i>	L = 750 P = 585 H = 560
Rumorosità <i>Noise ≤7m dB(A)</i>	80	Peso <i>Weight</i>	74 Kg
Servizio continuo orario <i>Continuous duty running time</i>	3 h	OHV25°, monocilindrico, raffreddamento aria, 4-tempi <i>OHV25°, single cylinder, forced air cooling, 4-stroke</i>	

Generatore a benzina

Gruppo elettrogeno monofase con motore a scoppio 4 tempi a benzina, flangiato ad un alternatore a 2 poli monofase. Avviamento con autoavvolgente ed elettrico a batteria. Quadro di comando con 2 prese CEE monofase 16A e 1 protettore termico.

Gasoline engine generator

Single phase generating set with 4-stroke gasoline engine coupled to single phase 2-pole alternator. Recoil or electric starter with battery.

Control panel with 2 single phase CEE plugs 16A and 1 termic protector.

Standard version

Optionals version

Motore - Engine		Generatore - Generator	
Potenza <i>Power</i>	13	Frequenza <i>Frequency</i>	50 Hz.
Aviamento <i>Start system</i>	manuale elettrico <i>recoil electric</i>	Tensione <i>Voltage</i>	230 Volt
Cilindrata <i>Displacement</i>	389 cc	Potenza uso continuo <i>Continuous duty power</i>	6 kVA
Tipo carburante <i>Fuel</i>	benzina <i>gasoline</i>	Potenza max <i>Max. power</i>	6,5 kVA
Capacità serbatoio <i>Tank capacity</i>	6,5 lt	Dimensioni <i>Dimensions</i>	L = 750 P = 585 H = 560
Rumorosità <i>Noise ≤7m dB(A)</i>	80	Peso <i>Weight</i>	80 Kg
Servizio continuo orario <i>Continuous duty running time</i>	2,5 h	OHV25°, monocilindrico, raffreddamento aria, 4-tempi <i>OHV25°, single cylinder, forced air cooling, 4-stroke</i>	

Generatore a benzina

Gruppo elettrogeno monofase con motore a scoppio 4 tempi a benzina, flangiato ad un alternatore a 2 poli monofase. Avviamento con autoavvolgente ed elettrico a batteria. Quadro di comando con 2 prese monofase CEE 16A e 2 protettori termici. Optional: pannello prese con 1 presa monofase CEE 32A, 1 presa monofase CEE 16A e 2 protettori termici.

Gasoline engine generator

Single phase generating set with 4-stroke gasoline engine coupled to single phase 2-pole alternator. Recoil or electric starter with battery. Control panel with 2 single phase CEE plugs 16A and 2 termic protectors. Optional: control panel with 1 single phase CEE plug 32A, 1 single phase CEE plug 16A and 2 termic protectors.



Motore - Engine		Generatore - Generator	
Potenza Power (HP / 3000 r.p.m.)	7,7	Carica batteria Charging battery voltage	12 V
Aviamento Start system	manuale elettrico recoil elettric	Amperaggio Current	8,3 A
Cilindrata Displacement	418 cc	Frequenza Frequency	50 Hz.
Tipo carburante Fuel	Diesel	Tensione Voltage	230 Volt
Capacità serbatoio Tank capacity	12,5 lt	Potenza uso continuo Continuous duty power	4,5 kW
Servizio continuo orario Continuous duty running time	8 h	Potenza max Max. power	4,8 kW
Dimensioni Dimensions	L = 745 P = 515 H = 725	Peso Weight	119 Kg

Generatore diesel

Gruppo elettrogeno monofase con motore Diesel, flangiato ad un alternatore a 2 poli monofase. Avviamento con autoavvolgente ed elettrico a batteria. Quadro di comando con 2 prese monofase 16A e con caricabatteria 12 volt.

Diesel engine generator

Single phase generating set with 4-stroke Diesel engine coupled to single phase 2-pole alternator. Recoil or electric starter with battery. Control panel with 2 single phase plugs 16A and 12 volt battery-charger.



Motore - Engine		Generatore - Generator	
Potenza Power (HP/3000 r.p.m.)	7,7	Carica batteria Charging battery voltage	12 V
Aviamento Start system	manuale elettrico recoil elettric	Amperaggio Current	8,3 A
Cilindrata Displacement	418 cc	Frequenza Frequency	50 Hz.
Tipo carburante Fuel	Diesel	Tensione - Voltage Potenza max - Max. power	400 Volt 4,8 kW
Capacità serbatoio Tank capacity	12,5 lt	Tensione - Voltage Potenza max - Max. power	230 Volt 1,5 kW
Servizio continuo orario Continuous duty running time	8 h	Dimensioni Dimensions	L = 745 P = 515 H = 725
		Peso Weight	119 Kg

Generatore diesel

Gruppo elettrogeno trifase con motore Diesel, flangiato ad un alternatore a 2 poli trifase. Aviamento con autoavvolgente ed elettrico a batteria. Quadro di comando con 1 presa trifase, 1 presa monofase e con caricabatteria 12 volt.

Diesel engine generator

Three phase generating set with 4-stroke Diesel engine coupled to three phase 2-pole alternator. Recoil or electric starter with battery. Control panel with 1 three phase plug, 1 single phase plug and 12 volt battery-charger.



Motore - Engine		Generatore - Generator	
Potenza Power (HP/3000 r.p.m.)	7,7	Carica batteria Charging battery voltage	12 V
Aviamento Start system	elettrico electric	Amperaggio Current	8,3 A
Cilindrata Displacement	418 cc	Frequenza Frequency	50 Hz.
Tipo carburante Fuel	Diesel	Tensione Voltage	230 Volt
Capacità serbatoio Tank capacity	14 lt	Potenza uso continuo Continuous duty power	4,2 kW
Servizio continuo orario Continuous duty running time	11 h	Potenza max Max. power	4,5 kW
Dimensioni Dimensions	L = 920 P = 530 H = 740	Peso Weight	165 Kg

Generatore diesel silenzioso

Gruppo elettrogeno monofase con motore Diesel, flangiato ad un alternatore a 2 poli monofase. Aviamento elettrico a batteria. Quadro di comando con 2 prese monofase e con caricabatteria 12 volt.

Silent diesel engine generator

Single phase generating set with 4-stroke Diesel engine coupled to single phase 2-pole alternator. Electric starter with battery.

Control panel with 2 single phase plugs and 12 volt battery charger.



Motore - Engine		Generatore - Generator	
Potenza Power (HP / 3000 r.p.m.)	7,7	Carica batteria Charging battery voltage	12 V
Aviamento Start system	elettrico electric	Amperaggio Current	8,3 A
Cilindrata Displacement	418 cc	Frequenza Frequency	50 Hz.
Tipo carburante Fuel	Diesel	Tensione - Voltage Potenza max - Max. power	400 Volt 4,5 kW
Capacità serbatoio Tank capacity	14 lt	Tensione - Voltage Potenza max - Max. power	230 Volt 1,4 kW
Servizio continuo orario Continuous duty running time	11 h	Peso Weight	165 Kg
		Dimensioni Dimensions	L = 920 P = 530 H = 740

Generatore diesel silenzioso

Gruppo elettrogeno trifase con motore Diesel, flangiato ad un alternatore a 2 poli trifase. Aviamento elettrico a batteria. Quadro di comando con 1 presa trifase, 1 presa monofase e con caricabatteria 12 volt.

Silent diesel engine generator

Three phase generating set with 4-stroke Diesel engine coupled to three phase 2-pole alternator. Electric starter with battery.

Control panel with 1 three phase plug, 1 single phase plug and 12 volt battery charger.



Motore - Engine		Generatore - Generator	
Potenza Power (HP/3000 r.p.m.)	7,7	Carica batteria Charging battery voltage	12 V
Avviamento Start system	elettrico electric	Amperaggio Current	8,3 A
Cilindrata Displacement	418 cc	Frequenza Frequency	50 Hz.
Tipo carburante Fuel	Diesel	Tensione Voltage	230 Volt
Capacità serbatoio Tank capacity	14 lt	Potenza uso continuo Continuous duty power	4,2 kW
Servizio continuo orario Continuous duty running time	11 h	Potenza max Max. power	4,5 kW
Dimensioni Dimensions	L = 920 P = 530 H = 740	Peso Weight	165 Kg

Generatore diesel silenzioso automatico

Gruppo elettrogeno monofase con motore Diesel, flangiato ad un alternatore a 2 poli monofase. Gestito da un quadro di controllo automatico.

Automatic silent diesel engine generator

Single phase generating set with 4-stroke Diesel engine coupled to single phase 2-pole alternator. Powered by automatic control panel.



Motore - Engine		Generatore - Generator	
Potenza Power (HP / 3000 r.p.m.)	7,7	Carica batteria Charging battery voltage	12 V
Aviamento Start system	elettrico electric	Amperaggio Current	8,3 A
Cilindrata Displacement	418 cc	Frequenza Frequency	50 Hz.
Tipo carburante Fuel	Diesel	Tensione - Voltage Potenza max - Max. power	400 Volt 4,5 kW
Capacità serbatoio Tank capacity	14 lt	Tensione - Voltage Potenza max - Max. power	230 Volt 1,4 kW
Servizio continuo orario Continuous duty running time	11 h	Peso Weight	165 Kg
		Dimensioni Dimensions	L = 920 P = 530 H = 740

Generatore diesel silenzioso automatico

Gruppo elettrogeno trifase con motore Diesel, flangiato ad un alternatore a 2 poli trifase. Gestito da un quadro di controllo automatico.

Automatic silent diesel engine generator

Three phase generating set with 4-stroke Diesel engine coupled to three phase 2-pole alternator. Powered by automatic control panel.



Idropulitrice professionale ad acqua fredda

Motore Loncin 4 tempi con avviamento a strappo autoavvolgente.

Pompa a pistoni in ceramica con sistema biella/manovella e testata in ottone stampato.

Manometro a bagno di glicerina.

Carrello con maniglia, ruote pneumatiche e sostegni per accessori.

Valvola by-pass automatica.

Dispositivo di regolazione pressione.

Aspirazione detergente in bassa pressione con comando tramite lancia.

Accessori inclusi

Lancia completa con dispositivo alta e bassa pressione. Tubo per alta pressione da mt. 10.

Ugelli con attacco rapido da 0°, 15°, 25°, 40° e detergente. Tubo alimentazione acqua da mt. 3.

Cold water professional high pressure washer

4-stroke Loncin motor with self-rewinding start. Ceramic piston pump with rod/crank system and brass head. Glycerin pressure gauge. Trolley with handle, pneumatic wheels and accessory holders. By-pass automatic valve. Pressure control device. Low pressure detergent suction through the lance.

Included accessories

Complete lance with high-low pressure device. Mt. 10 high pressure hose.

Rapid coupling nozzles 0°, 15°, 25°, 40° and detergent. Mt. 3 alimentation hose.

Tipo Type	Pressione Massima Max. Pressure		Portata Water Flow		N° giri/1'	Potenza Power	Peso Weight	Imballo Packaging		
	bar	psi	gph	l/h	r.p.m.	HP	kg	L	P	H
LD 12/186	186	2700	198	756	3400	6,5	45	920	550	720



Idropultrice professionale ad acqua fredda

Motore Loncin 4 tempi con avviamento a strappo autoavvolgente ed elettrico completo di batteria a secco. Pompa a pistoni in ceramica sistema biella/manovella e testata in ottone stampato. Manometro a bagno di glicerina con maniglia, ruote pneumatiche e sostegni per accessori. Valvola by-pass automatica. Dispositivo di regolazione pressione. Aspirazione detergente in bassa pressione con comando tramite lancia.

Accessori inclusi

Lancia completa con dispositivo alta e bassa pressione. Tubo per alta pressione da mt.10 Ugelli con attacco rapido da 0°, 15°, 25°, 40° e detergente. Tubo alimentazione acqua da mt.3.

Cold water professional high pressure washer

4-stroke Loncin motor with self-rewinding and electric start complete with dry battery. Ceramic piston pump with rod/crank system and brass head. Glycerin pressure gauge. Trolley with handle, pneumatic wheels and accessory holders. By-pass automatic valve. Pressure control device. Low pressure detergent suction through the lance.

Included accessories

Complete lance with high-low pressure device. Mt. 10 high pressure hose. Rapid coupling nozzles 0°, 15°, 25°, 40° and detergent. Mt.3 alimentation hose.



Tipo Type	Pressione Massima Max. Pressure		Portata Water Flow		N° giri/1' r.p.m.	Potenza Power HP	Peso Weight kg	Imballo Packaging		
	bar	psi	gph	l/h				L	P	H
LD 15/220	220	3200	240	900	3400	9	76	880	700	830



Idropultrice professionale ad acqua fredda

Motore Loncin 4 tempi con avviamento a strappo autoavvolgente ed elettrico completo di batteria a secco. Pompa a pistoni in ceramica con sistema biella/manovella e testata ottone stampato. Manometro a bagno di glicerina. Carrello con maniglia, ruote pneumatiche e sostegni per accessori. Valvola by-pass automatica. Dispositivo di regolazione pressione. Aspirazione detergente in bassa pressione con comando tramite lancia.

Accessori inclusi

Lancia completa con dispositivo alta e bassa pressione. Tubo per alta pressione da mt. 10 Ugelli con attacco rapido da 0°, 15°, 25°, 40° e detergente. Tubo alimentazione acqua da mt. 3.



Cold water professional high pressure washer

4-stroke Loncin motor with self-rewinding and electric start complete with dry battery. Ceramic piston pump with rod/crank system and brass head. Glycerin pressure gauge. Trolley with handle, pneumatic wheels and accessory holders. By-pass automatic valve. Pressure control device. Low pressure detergent suction through the lance.

Included accessories

Complete lance with high-low pressure device. Mt. 10 high pressure hose. Rapid coupling nozzles 0°, 15°, 25°, 40° and detergent. Mt. 3 alimentation hose.

Tipo Type	Pressione Massima Max. Pressure		Portata Water Flow		N° giri/1' r.p.m.	Potenza Power HP	Peso Weight kg	Imballo Packaging		
	bar	psi	gph	l/h				L	P	H
LD 18/248	248	3600	270	1092	3400	13	85	880	700	880



Motosaldatrice a benzina

Motosaldatrice in corrente alternata caratterizzata da alta affidabilità, 2 poli autoregolata a condensatore, senza spazzole (brushless) è dotata di protezione termica autoripristinabile contro i sovraccarichi, con possibilità di utilizzo di elettrodi rutili ed acidi con diametro massimo fino a 3.25 mm. Dotata di selettore ad 8x2 posizioni che permette di variare la corrente di saldatura e di regolare la tensione di uscita del generatore monofase.

Motore - Engine		Saldatrice in A.C. - A.C. Welder	
Potenza Power	13	Corrente di saldatura Welding current	200A - 35% 180A - 60%
Aviamento Start system	manuale elettrico recoil elettric	Diametro elettrodi Electrode diameter	3,25 mm max.
Cilindrata Displacement	389 cc	Protezione Protection	IP 23
Tipo carburante Fuel	benzina gasoline	Classe isolamento Insulation class	H
Capacità serbatoio Tank capacity	6,5 lt	Generatore in A.C. - A.C. Generator	
		Potenza max Max. power	6,5 kVA
Servizio continuo orario Continuous duty running time	2,5 h	Tensione Voltage	230 V
		Frequenza Frequency	50 Hz.
OHV25°, monocilindrico, raffreddamento aria, 4-tempi OHV25°, single cylinder, forced air cooling, 4-stroke			

Gasoline engine welding machine

The alternate current engine welding machine is identified by high reliability, capacitor, self-regulated, brushless, 2 pole, is equipped with auto-resettable thermal breaker against overload, with possibility to weld rutilic and acid electrodes with a maximum diameter up to 3.25 mm.

Supplied with 8x2 positions selector which allows to adjust the welding current and to adjust the output voltage of the single-phase generator.



Motosaldatrice diesel

Motosaldatrice in corrente alternata caratterizzata da alta affidabilità, 2 poli autoregolata a condensatore, senza spazzole (brushless) è dotata di protezione termica autoripristinabile contro i sovraccarichi, con possibilità di utilizzo di elettrodi rutili ed acidi con diametro massimo fino a 3.25 mm. Dotata di selettore ad 8x2 posizioni che permette di variare la corrente di saldatura e di regolare la tensione di uscita del generatore monofase.

Motore - Engine		Saldatrice in A.C. - A.C. Welder	
Potenza Power	9,6	Corrente di saldatura Welding current	180A - 35% 125A - 60%
Aviamento Start system	manuale elettrico recoil elettric	Diametro elettrodi Electrode diameter	3,25 mm max.
Cilindrata Displacement	418 cc	Protezione Protection	IP 23
Tipo carburante Fuel	Diesel	Classe isolamento Insulation class	H
Capacità serbatoio Tank capacity	6,5 lt/h	Generatore in A.C. - A.C. Generator	
		Potenza max - Max. power	5 kVA
Servizio continuo orario Continuous duty running time	4 h	Tensione - Voltage	230 V
		Frequenza - Frequency	50 Hz.

Diesel engine welding machine

The alternate current engine welding machine is identified by high reliability, capacitor, self-regulated, brushless, 2 pole, is equipped with auto-resettable thermal breaker against overload, with possibility to weld rutil and acid electrodes with a maximum diameter up to 3.25 mm.

Supplied with 8x2 positions selector which allows to adjust the welding current and to adjust the output voltage of the single-phase generator.



Set manichetta
(Mod. MSHP 50)

Flat hose set
(Mod. MSHP 50)



Batteria
(Mod. Generatore LC 3800)

Battery
(Mod. Generator LC 3800)



**Kit cavetti
motosaldatrice**
(Mod. LGM-HGM)

Welding kit cable
(Mod. LGM-HGM)



Batteria
(Mod. Generatori
LC 5000-6500-8000)

Battery
(Mod. Generators
LC 5000-6500-8000)



Kit Carrello LC
(Mod. Generatori LC)

LC Trolley Kit
(Mod. Generators LC)

Kit Carrello LS
(Mod. Generatori LS)

LS Trolley Kit
(Mod. Generators LS)





G160 HP 5,5

Monocilindrico, raffreddamento aria, 4-tempi / Single cylinder, Forced Air Cooled, 4 stroke

Potenza nominale / Rated power	3,1 kW / 3600 rpm	Capacità serbatoio olio / Oil Capacity	0,6 l.
Coppia massima / Max.torque	10,5 Nm / 3000 rpm	Rumorosità / Noise level	≤ 70 db (A)
Sistema avviamento / Starting System	Manuale / Recoil	Alesaggio corsa / Bore stroke	68 x 45 mm
Cilindrata / Displacement	163 cc	Dimensione / Dimension (LxWxH)	312 x 362 x 335 mm
Capacità serbatoio/Fuel Tank Capacity	3,6 l.	Peso a secco / Dry weight	15 Kg

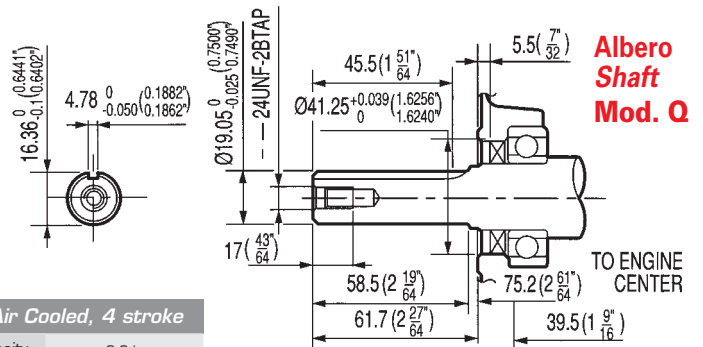
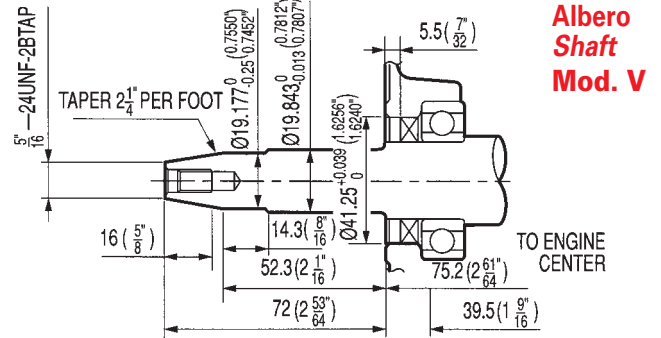

G200 HP 6,5

Monocilindrico, raffreddamento aria, 4-tempi / Single cylinder, Forced Air Cooled, 4 stroke

Potenza nominale / Rated power	3,8 kW / 3600 rpm	Capacità serbatoio olio / Oil Capacity	0,6 l.
Coppia massima / Max.torque	13 Nm / 3000 rpm	Rumorosità / Noise level	≤ 70 db (A)
Sistema avviamento / Starting System	Manuale / Recoil	Alesaggio corsa / Bore stroke	68 x 54 mm
Cilindrata / Displacement	196 cc	Dimensione / Dimension (LxWxH)	312 x 376 x 335 mm
Capacità serbatoio/Fuel Tank Capacity	3,6 l.	Peso a secco / Dry weight	16 Kg

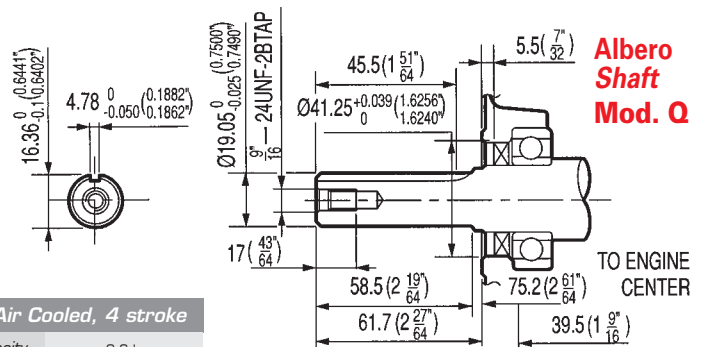
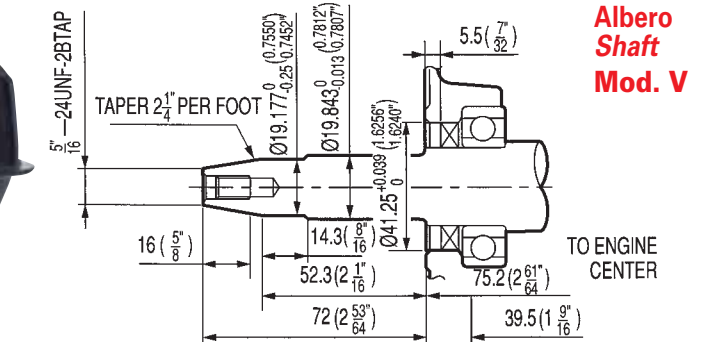



G240 HP 8

Monocilindrico, raffreddamento aria, 4-tempi / Single cylinder, Forced Air Cooled, 4 stroke

Potenza nominale / Rated power	5,1 kW / 3600 rpm	Capacità serbatoio olio / Oil Capacity	1,1 l.
Coppia massima / Max.torque	16,5 Nm / 3000 rpm	Rumorosità / Noise level	≤ 80 db (A)
Sistema avviamento / Starting System	Manuale elettrico Recoil electric	Alesaggio corsa / Bore stroke	73 x 58 mm
Cilindrata / Displacement	242 cc	Dimensione / Dimension (LxWxH)	380 x 430 x 410 mm
Capacità serbatoio/Fuel Tank Capacity	6 l.	Peso a secco / Dry weight	25 Kg

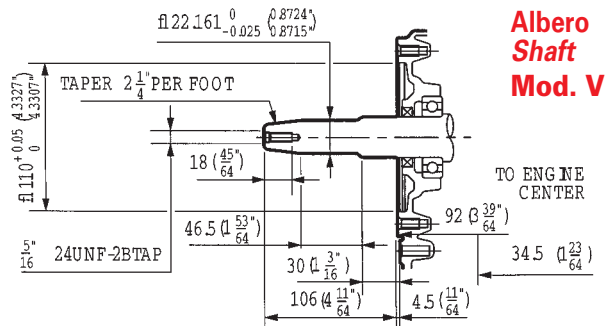

Albero Shaft Mod. V

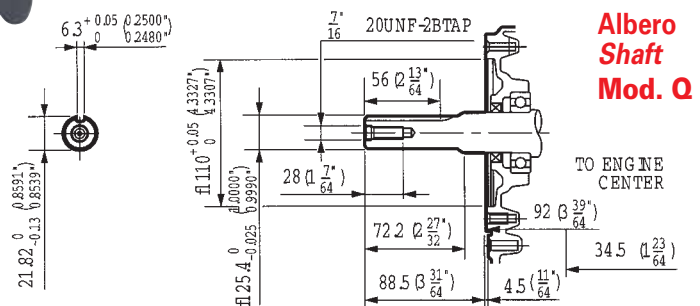

Albero Shaft Mod. Q



G270 HP 9

Monocilindrico, raffreddamento aria, 4-tempi / Single cylinder, Forced Air Cooled, 4 stroke

Potenza nominale / Rated power	5,8 kW / 3600 rpm	Capacità serbatoio olio / Oil Capacity	1,1 l.
Coppia massima / Max.torque	19 Nm / 3000 rpm	Rumorosità / Noise level	≤ 80 db (A)
Sistema avviamento / Starting System	Manuale elettrico Recoil electric	Alesaggio corsa / Bore stroke	77 x 58 mm
Cilindrata / Displacement	270 cc	Dimensione / Dimension (LxWxH)	380 x 430 x 410 mm
Capacità serbatoio/Fuel Tank Capacity	6 l.	Peso a secco / Dry weight	26 Kg

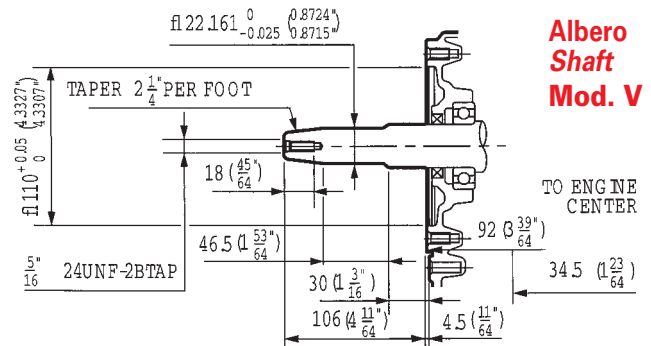

Albero Shaft Mod. V

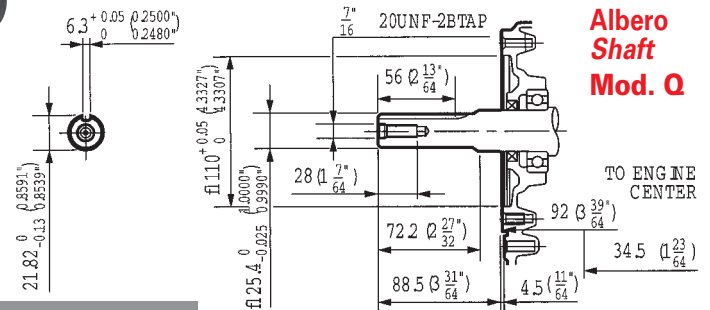

Albero Shaft Mod. Q



G340 HP 11

Monocilindrico, raffreddamento aria, 4-tempi / Single cylinder, Forced Air Cooled, 4 stroke

Potenza nominale / Rated power	7 kW / 3600 rpm	Capacità serbatoio olio / Oil Capacity	1,1 l.
Coppia massima / Max.torque	23,5 Nm / 3000 rpm	Rumorosità / Noise level	≤ 80 db (A)
Sistema avviamento / Starting System	Manuale elettrico Recoil electric	Alesaggio corsa / Bore stroke	82 x 64 mm
Cilindrata / Displacement	337 cc	Dimensione / Dimension (LxWxH)	405 x 450 x 443 mm
Capacità serbatoio/Fuel Tank Capacity	6,5 l.	Peso a secco / Dry weight	31 Kg

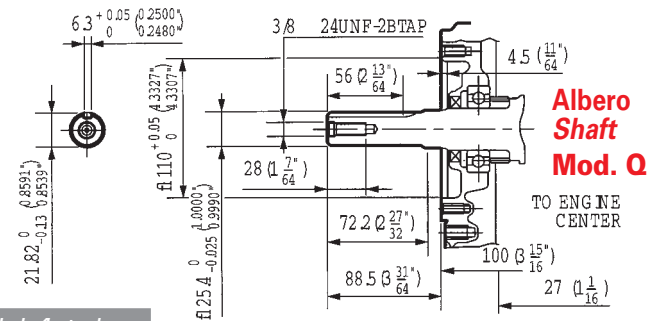
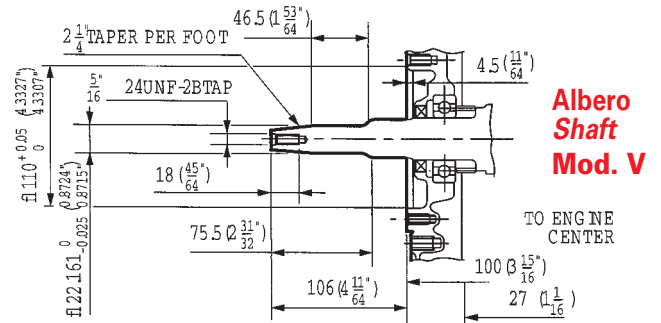

G390 HP 13

Monocilindrico, raffreddamento aria, 4-tempi / Single cylinder, Forced Air Cooled, 4 stroke

Potenza nominale / Rated power	7,5 kW / 3600 rpm	Capacità serbatoio olio / Oil Capacity	1,1 l.
Coppia massima / Max.torque	26,5 Nm / 3000 rpm	Rumorosità / Noise level	≤ 80 db (A)
Sistema avviamento / Starting System	Manuale elettrico Recoil electric	Alesaggio corsa / Bore stroke	88 x 64 mm
Cilindrata / Displacement	389 cc	Dimensione / Dimension (LxWxH)	405 x 450 x 443 mm
Capacità serbatoio/Fuel Tank Capacity	6,5 l.	Peso a secco / Dry weight	31 Kg

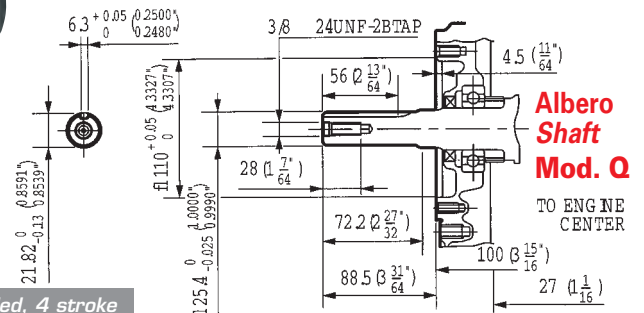
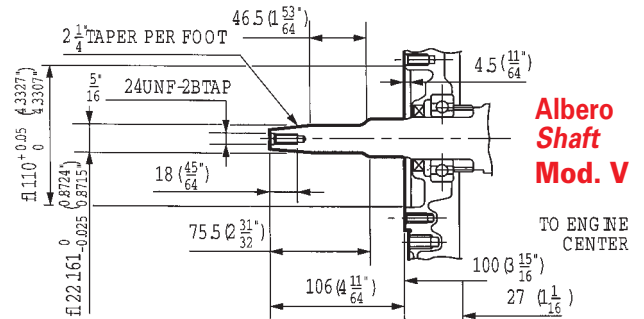

HL 170 FA

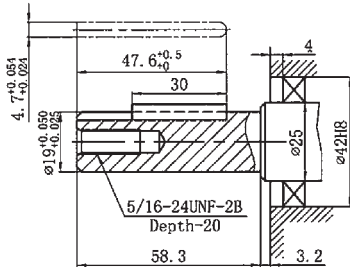

Albero Shaft Mod. K1

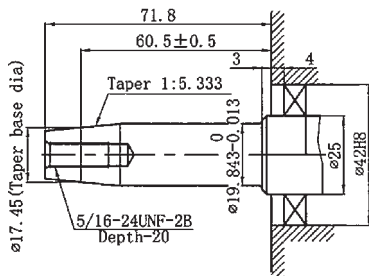

Albero Shaft Mod. G1

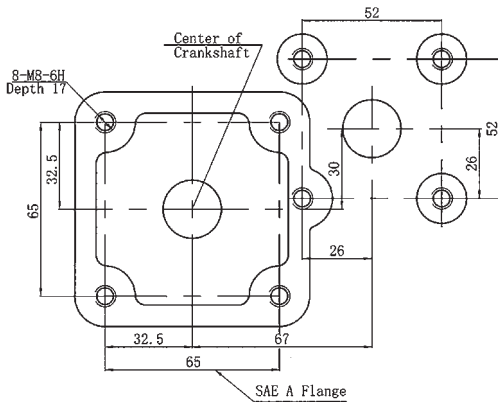

Flangia Flange Mod. K1 - G1

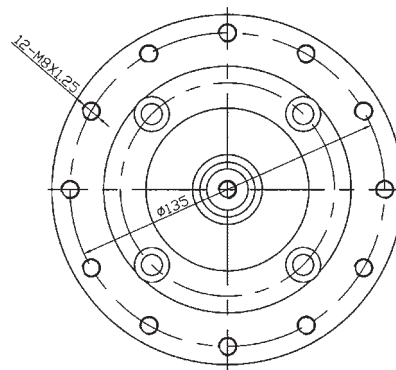

Flangia Flange Mod. G4

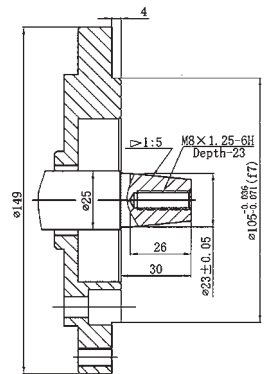

Albero Shaft Mod. G4

Monocilindrico, raffreddamento aria, 4-tempi diesel / Single-cylinder, forced air-cooling, 4-stroke diesel

Cilindrata / Displacement	219 cc	
Alesaggio corsa / Bore stroke	70 x 57 mm	
Giri motore / Engine speed	3000 rpm	3600 rpm
Max potenza resa / Max. output	3,8 hp	4,2 hp
Potenza uso continuo / Continuous output	3,4 hp	3,8 hp
Sistema avviamento / Starting system	Manuale / Recoil	
Capacità serbatoio / Fuel tank capacity	2,5 l.	
Capacità serbatoio olio / Oil capacity	0,8 l.	
Dimensioni / Dimensions (L x W x H)	332 x 392 x 416 mm	
Peso a secco (Manuale) / Dry weight (Recoil)	26 Kg	

HL 178 FA-E

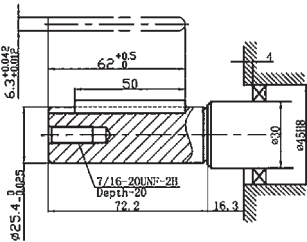

Albero Shaft Mod. K1

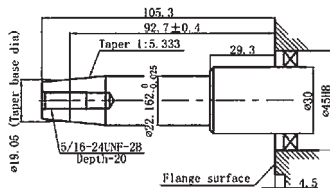

Albero Shaft Mod. G1

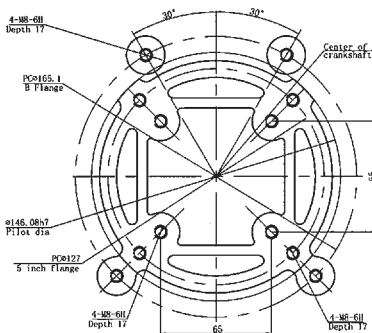

Flangia Flange Mod. K1 - G1

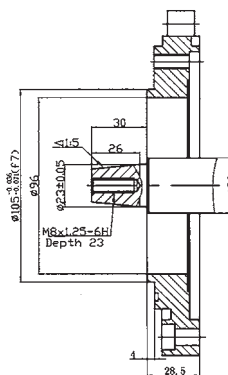

Albero Shaft Mod. G4

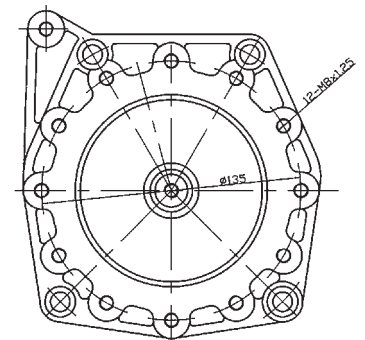

Flangia Flange Mod. G4

Monocilindrico, raffreddamento aria, 4-tempi diesel / Single-cylinder, forced air-cooling, 4-stroke diesel

Cilindrata / Displacement	306 cc	
Alesaggio corsa / Bore stroke	78 x 64 mm	
Giri motore / Engine speed	3000 rpm	3600 rpm
Max potenza resa / Max. output	5,5 hp	6 hp
Potenza uso continuo / Continuous output	5 hp	5,5 hp
Sistema avviamento / Starting system	Manuale elettrico / Recoil electric	
Capacità serbatoio / Fuel tank capacity	3,5 l.	
Capacità serbatoio olio / Oil capacity	1,1 l.	
Dimensioni / Dimensions (L x W x H)	383 x 421 x 450 mm	
Peso a secco (Manuale) / Dry weight (Recoil)	33 Kg	
Peso a secco (Elettrico) / Dry weight (Electric)	38 Kg	

HL 186 FA-E

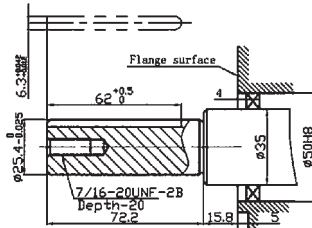

Albero Shaft Mod. K1

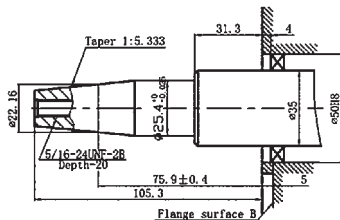

Albero Shaft Mod. G1

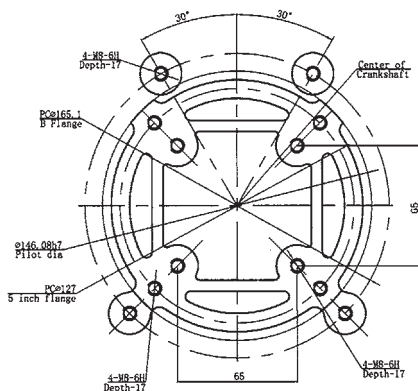

Flangia Flange Mod. K1 - G1

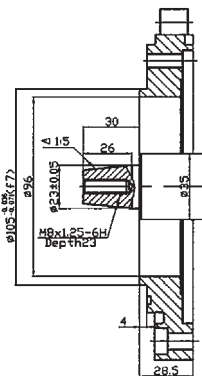

Albero Shaft Mod. G4

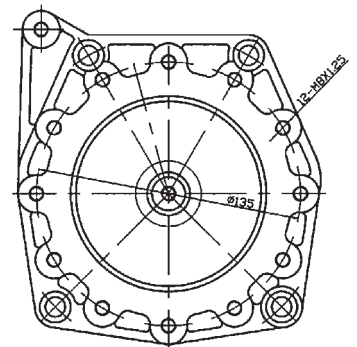

Flangia Flange Mod. G4

Monocilindrico, raffreddamento aria, 4-tempi diesel / Single-cylinder, forced air-cooling, 4-stroke diesel

Cilindrata / Displacement	418 cc	
Alesaggio corsa / Bore stroke	86 x 72 mm	
Giri motore / Engine speed	3000 rpm	3600 rpm
Max potenza resa / Max. output	8,8 hp	9,6 hp
Potenza uso continuo / Continuous output	7,7 hp	8,6 hp
Sistema avviamento / Starting system	Manuale elettrico / Recoil electric	
Capacità serbatoio / Fuel tank capacity	5,5 l.	
Capacità serbatoio olio / Oil capacity	1,65 l.	
Dimensioni / Dimensions (L x W x H)	417 x 470 x 494 mm	
Peso a secco (Manuale) / Dry weight (Recoil)	48 Kg	
Peso a secco (Elettrico) / Dry weight (Electric)	53 Kg	



Speroni S.p.a. - 42024 Castelnovo di Sotto (Reggio Emilia) ITALY - Via S. Biagio, 59
tel. 0522 487011 - fax (Italy) +39 0522 487019 - fax (World) +39 0522 683070
www.speroni.it - speroni@speroni.it